

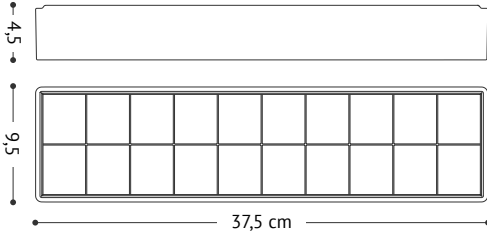

## Product data sheet

# LightUnit

by port:safety



### Mechanical Data

Weight	1,8 kg
Dimensions	37,5 x 9,5 x 4,5 cm
Casing material	PA66 GF30, Carbon Black
Lid material	PMMA, Transparent
Gasket material	Silicone, Black
Valve material	PA66, IP68
Screws material	A4 316 Stainless Steel
Waterproof	IP68
Impact resistance	SolarPanel IK08, Body IK10
Expected lifetime	+20 years
Expected battery life	8-10 years (replaceable battery)

### Technical Data

LED Type	XP-G3
LED Color Temp.	4000 K
CRI	>80
<b>Solar Powered</b>	
Solar Cell Type	Monocrystalline
Max Output Voltage	10,8 V
Peak Power	4,9 W
Battery Type	NiMh
Battery Capacity	3500mAh
Bat. Nominal Voltage	6,0 V
Illuminance	Up to 185 Lux
<b>Grid Powered</b>	
Power Grid	85-305 V AC (custom 24 V AC)
Frequency	47-63 Hz
Standard Cable Length	2,0 m
Illuminance	185 Lux (custom max. 745 lux)

### LightUnit with Wallmount

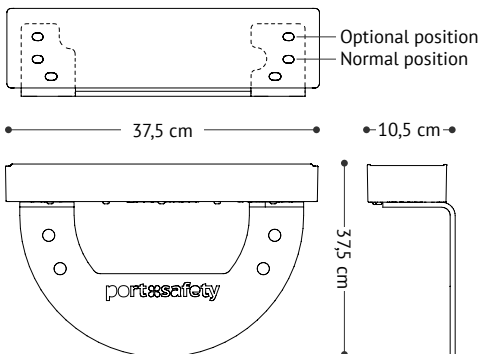

The Wallmount is an optional add-on made of 6mm A4 316 Stainless Steel. Use appropriate M12 fasteners for installation.

### Safety at night

The LightUnit illuminates a rescue ladder's rungs and side rails at night, providing visibility at night and clear direction to safety.

### Two versions

The LightUnit comes in two versions: Solar Powered and Grid Powered.

**Solar Powered** version operates autonomously in locations below 64°N. A solar panel charges the battery pack during daytime and the LightUnit's power saving algorithm ensures functionality all year round\*. From a fully charged battery the LightUnit will function for +30 nights if the solar panel is covered.

**Grid Powered** version connects to the local power grid and is the best choice at locations above 64°N or in places with shady surroundings such as next to buildings, under bridges etc. There is no active algorithm calculating light intensity in the Grid Powered LightUnit. It runs with maximum light intensity every night. The Light Sensor determines when to turn on/off.

### Installation

**Installation on a LifeLadder®** includes two Stainless Steel Supports, that are easy to mount in the upper bracket of the LifeLadder®. Retrofitting the LightUnits does not require uninstalling the the LifeLadder®.

**Installation on a 3rd party ladder** includes a Wall Mount, dimensioned to fit any standard dock ladder. The Wallmount is fixed to the quay wall using M12 expansion bolts, french screws or similar (not included with the Wallmount).

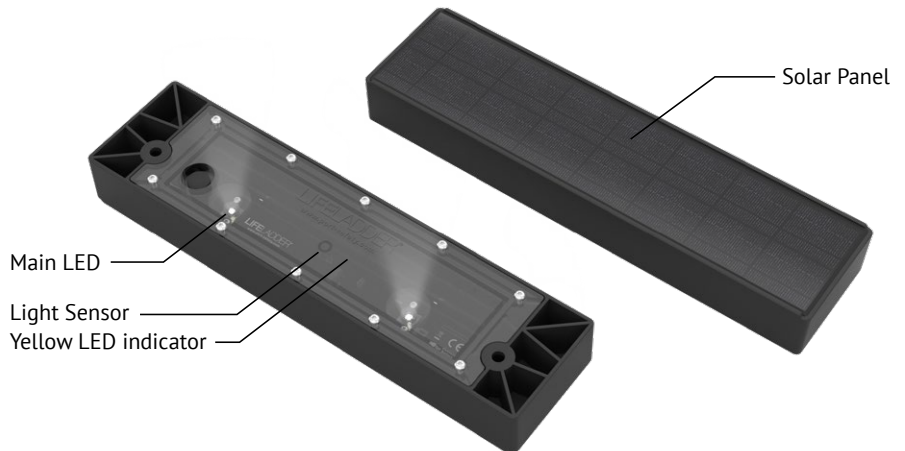

### ON/OFF

There is no ON/OFF button on the LightUnit. At delivery the Solar Powered LightUnit is in Factory Sleep Mode. When the solar panel is exposed to light, the yellow LED indicator will flash. After 30 minutes of constant light on solar panels the LightUnit wakes up. At normal operation when the Light Sensor is exposed to darkness/light for 3 min., the main LEDs turns on/off.

### Algorithm

First night after waking up from Factory Sleep Mode the Solar Powered LightUnit runs with lowest light intensity. Based on the length of the night and energy harvested during daytime, the LightUnit will adjust its light intensity a bit once a day. It can take 4-5 days after installation for the algorithm to adjust the light intensity to the correct level.

### Shade

For optimal energy harvest the Solar Powered LightUnit must be installed with the solar panel flush (in level) with the top of the quay to avoid shade. This is especially important at a north oriented quay. If the solar panel is covered, the algorithm will each night reduce the light intensity to preserve energy. Whenever the solar panel receives light, the intensity will increase.

\*To function all year round up to 64°N, the Solar Powered LightUnit's solar panel must be clean and fully exposed to sunlight. Shadows on the solar panel from the waterfront, handrails, buildings, trees etc. will reduce the LightUnit's ability to charge and may cause temporary depletion of the batteries.